



New Gate

**MC300CR
MR300CR/220**

Instrucciones MC300CR-MR300CR/220-v20190430



4 Versioni:

MR300/CR Trifase per cancelli max 3000 kg.

MR300/CRI con centrale incorporata.

MR300/CR220 Monofase per cancelli max 2500 kg.

MR300/CR220I con centrale incorporata.

COMPATTO e facile da installare grazie al carter metallico completamente amovibile.

VERSATILE: con gli accessori forniti in dotazione.

SICURO: col riduttore a vite senza fine irreversibile non necessita di elettroserratura.

LUNGA DURATA: motore 400 V. Trifase ventilato o monofase 230 V. ventilato - 2 finecorsa elettrici - riduttore e con vite senza fine in acciaio e ingranaggio in bronzo.

SILENZIOSO: trasmissione a cinghia e frizione a secco registrabile.

COMANDO MANUALE: di emergenza con leva rapida.

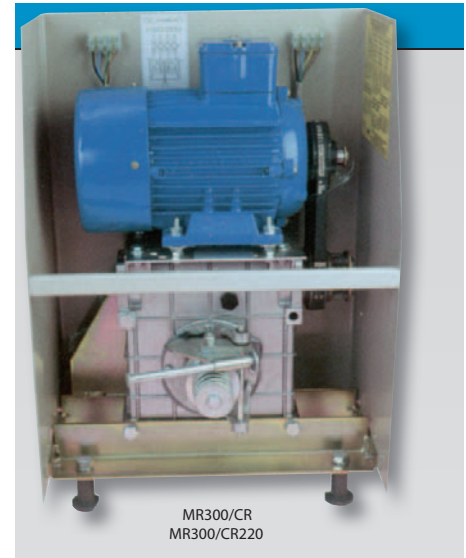

MR300/CR
MR300/CR220



Manufactured in 4 type:

MR300/CR 3phase for gates max 3000 kg. - **MR300/CRI** control-box incorporated.

MR300/CR220 singlephase for gates max 2500 kg. - **MR300/CR220I** control-box incorporated.

COMPACT and easy to install with the carter fully removable painted and with key.

VERSATILE: with the accessories.

SAFE: reducer not reversible. No need electrolock.

LONG LIFE: motor 400 V. 3phase fan cooled a.c. or Singlephase 230 V - 2 limit-switches electric. Steel screw and bronze internal gear.

CONFORTABLE: transmission between motor and reducer by pulley and belt and adjustable clutch.

EMERGENCY: manual release by fast lever.



Fabriqué en 4 versions:

MR300/CR 3phase pour portails max 3000 kg. - **MR300/CRI** centrale incorporée.

MR300/CR220 1phase pour portails max 2500 kg. - **MR300/CR220I** centrale incorporée.

COMPACT et facile a installer avec le carter complètement amovible en acier laqué au four.

VERSATILE: avec les accessoires.

SUR: reducteur irreversible.

LONGUE DUREE: moteur 400 V. Triphasé ventilé ou Mono 230 V.a.c. Ingranage en bronze.

SOUPLE: transmission primaire par courroi et poulie avec embrayage à sec réglable - fin de course électriques.

DEPANNAGE MANUEL: par levier rapide a clef.



4 Tipos:

MR300/CR 3phase para puertas max 3000 kg. - **MR300/CRI** centralita incorporada.

MR300/CR220 1phase para puertas max 2500 kg. - **MR300/CR220I** centralita incorporada.

COMPACTO y facil de instalar - carter metálico amovible con llave.

VERSATILE: gracias a los accesorios.

SEGURO: reductor irreversible.

SOLIDO: motor 400 V. trifásico ventilado o 230 V.a.c. monofásico, engranaje en bronce.

PRÁCTICO: finales de carreras electricos. Embraje regulable.

MANDO MANUAL: Desbloqueo manual para lleva rapida con llave.



4 AUSFÜHRUNGEN

MR300/CR Dreiphas für Gittertüre max 3000 kg.

MR300/CRI Eingebaute Zentrale.

MR300/CR220 Einzelphase für Gittertüre max 2500 kg.

MR300/CR220I Eingebaute Zentrale.

KOMPAKT und einfach zu installieren dank dem völlig abnehmbaren Metallgehäuse.

GEWANDT mit den ausgestatteten Zubehörteilen.

SICHER mit dem irreversibelen (Schraube ohne Ende) Reduktor und Schraube ohne Ende braucht sie keine Elektroverschluß.

LANGE DAUERHAFTIGKEIT Motor: gelüfteter Dreiphas 400v oder gelüfteter Einzelphase 230v; 2 elektrische Endschalter; Untersetzungsgetriebe mit Schraube ohne Ende aus Stahl und Getriebe aus Bronze.

LEISE Riemenantrieb und einstellbare Trockenkupplung.

NOTHANDSTEUERUNG mit schnell Hebel.



MR300/CRI
MR300/CR220I

SCHEMA FUNZIONALE - OPERATIONAL DIAGRAM - SCHÉMA DE PRINCIPE
ESQUEMA FUNCIONAL - FUNKTIONSPPLAIN

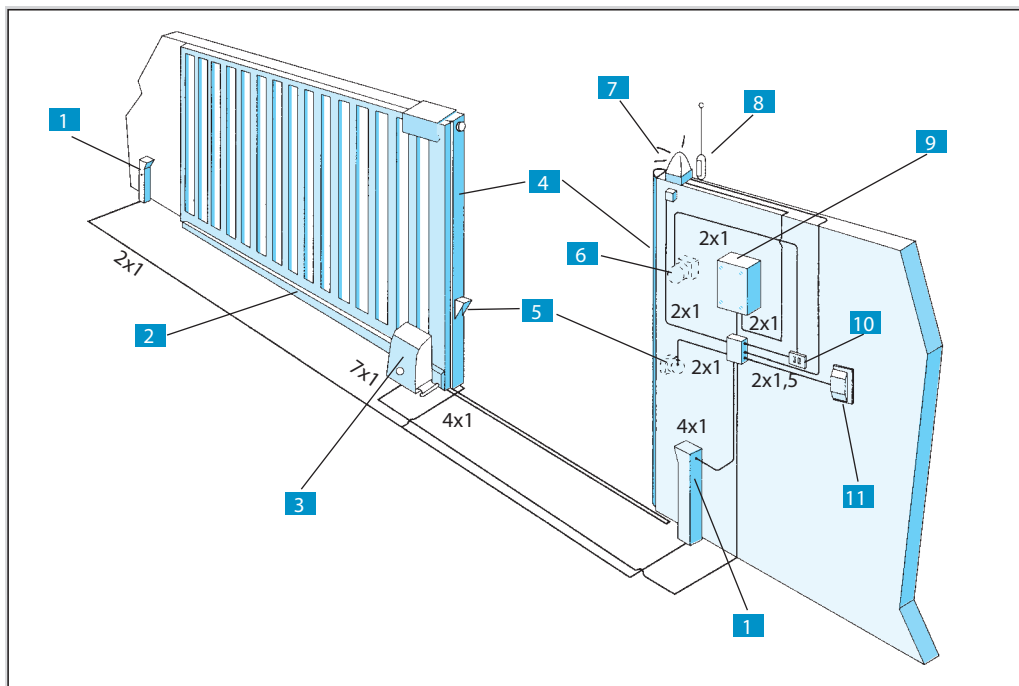

- 1 Fotocellule
Photocells
Photozellules
Fotocélulas
Photozelle
- 2 Cremagliera
Rack
Crémaillère
Cremallera
Zahnstange
- 3 Motoriduttore
Gear motor
Motoreducteur
Motorreductor
Antrieb
- 4 Coste sensibili
Safety hedges
Barre palpeuse
Barra de seguridad
Empfindliche Rücken
- 5 Fotocellule
Photocells
Photozellules
Fotocélulas
Photozelle
- 6 Selettore a chiave
Key contador
Contacteur a clé
Selector de llave
Schlüsselschalter
- 7 Lampeggiatore
Warning light
Clignotant
Luz intermitente
Blinkleuchte
- 8 Antenna
Aerial
Antenne
Antena
Antenne
- 9 Centrale elettronica
Electronic control unit
Centrale électronique
Central electrónica
Elektroschrank
- 10 Pulsantiera
Push-switch
Poussoir
Pulsador
Druckknopf
- 11 Interruttore generale
Main switch
Interrupteur de ligne
Interruptor general
Schalter

MR300/CR - MR300/CR220 (MR300/CR1 - MR300/CR220I)

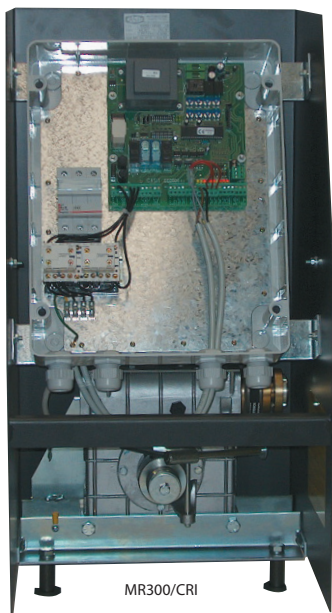
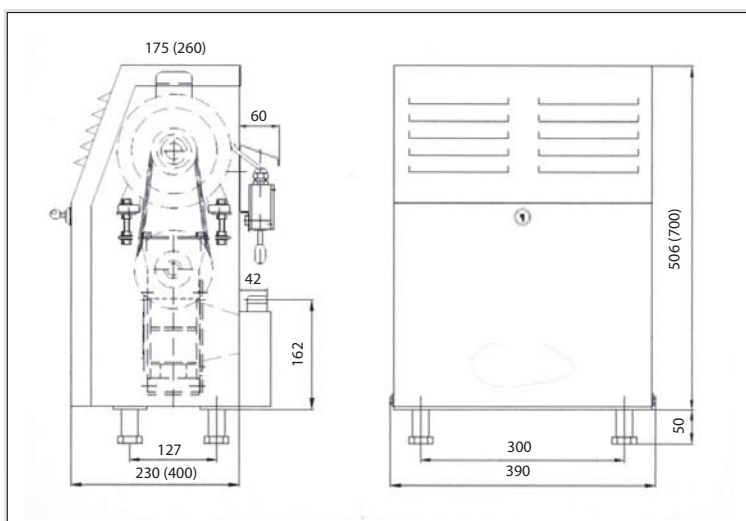

MR300/CR1

LA SICUREZZA E DURATA

del prodotto sono garantiti da una accurata progettazione e la conformità alle norme.

THE SAFETY AND DURABILITY

are guaranteed a precise design according to the standard.

LA SECURITÉ ET LA DURÉE

du produit sont garanties par un projet soigné et la conformité aux normes.

LA SEGURIDAD Y LA DURACIÓN





del producto están garantizadas gracias al cuidadoso diseño de las mismas y a que cumplen la normativa.

DIE SICHERHEIT UND DIE DAUERHAFTIGKEIT

der Erzeugnisse werden von einer sorgfältigen Planung nach den Regeln und von der Benutzung von erstklassigen Bestandteilen garantiert

CARATTERISTICHE TECNICHE

TECHNICALS DATA / CARACTERISTIQUES TECHNIQUES / CARACTERISTICAS TECNICAS / TECHNISCHE DATEN

					MR300/CR MR300/CRI	MR300/CR220 MR300/CR220I
Tensione alimentazione	Power supply	Alimentation	Alimentaciòn	Spannungsversorgung	240/400 V.a.c. 3Ph - 50/60 Hz	230 V.a.c. 1Ph - 50/60 Hz
Centrale incorporata	Control-box incorporated	Centrale incorporée	Centralita incorporada	Eingebaute Zentrale	MR300/CRI	MR300/CR220I
Senza centrale	Without control-box	Sans centrale	Sin centralita	Ohne Zentrale	MR300/CR	MR300/CR220
Grado protezione	Protection	Protection	Protecciòn	Beschützung	CLASSE F	
Motore	Motor	Moteur	Motor	Motor	240/400 V.a.c. 3Ph 750 Watt 3,5/2,2 Amp 1.400 rpm	230 V.a.c. 1Ph 550 Watt 3,2 Amp cap 30Mf 1.400 rpm
Velocità	Speed	Vitesse	Velocidad	Drehzahl der Triebwelle	9 ml/min. ÷ (pig. M = 4 Z25)	
Giri albero	Turns axis motor	Tours de rotation axe	Rotaciòn del eje	Geschwindigkeit	30,3/min.	
Lubrificazione	Lubrication	Lubrification	Lubrificaciòn	Schmierung	Olio - Oil - Huile Aceite - Öl	
Fine corsa	Limit switch	Fin de course	Final de carrera	Öffnung Endschalter	2 - Electr.	
Temp. esercizio	Temp. exercise	Temp. exercice	Temp. ejercicio	Betriebtemperatur	-20° +70° C	
Funzionamento	Utilization	Fonctionnement	Funcionamento	Betrieb	Intens.	
Forza spinta	Power	Poussée	Fuerza de tiro	Treibkraft	2450 N	1800 N
Coppia	Torque	Couple	Par	Drehmoment	80 Nm	32 Nm
Peso operatore	Weight operator	Poids operateur	Peso operador	Gewicht Operatoren	MR300/CR 44 kg. MR300/CRI 60 kg.	MR300/CR220 44 kg. MR300/CR220I 60 kg.
Peso cancello indicativo	Weight-gate indicative	Poids-portail indicatif	Peso puerta indicativo	Gewicht Gittertür (indikativ)	Max 3.000 kg.	Max 2.500 kg.

N.B: Installare i dispositivi previsti dalle norme vigenti / To install the safety devices following the standard / Installer les dispositifs de securitée prevus par les normes / Instale los dispositivos previstos por las normas vigentes / Während der Installation immer die geltenden Regel achten und die Schutzvorrichtung benutzen.



New Gate

Pol. Ind. Sud-Oest C/Bernat de Rocabertí, 16 Sabadell (Barcelona) 08205
Tel.: 93 721 97 55 e-mail: info@newgate.es

www.newgate.es